



Thank you for purchasing this anti-sway bar kit. Please read through these instructions before installation.

Installation Instructions

Front Anti-Sway Bar Kit for the Chevy/GMC 4500 and 5500

Part #1109-158
1-5/8" diameter



INTRODUCTION

Thank you for purchasing this anti-sway bar kit. This kit is designed to improve the handling characteristics of your vehicle by reducing the body roll and balancing the weight transfer during cornering. The anti-sway bar kit is engineered for long life and trouble-free performance. For maximum suspension control, use this kit along with our front sway bar kit.

All the hardware needed for installation is included in this kit. Refer to the PARTS LIST in these instructions to identify the parts.

SUGGESTED TOOLS

The following tools are suggested to complete the installation procedures:

- General hand tools
- Torque wrench
- Vise-grips

WARNING

Failure to follow these instructions can result in property damage, personal injury or even death.

- If raising the vehicle to install the anti-sway bar, always support the vehicle with jack stands at both frame rails or at the rear axle before working underneath. Ensure that the jack stands are securely positioned, and are rated at or above the weight of the vehicle.
- The installer must read the instructions and use all bolts and parts supplied. Use only the parts supplied by ROADMASTER to install this kit.
- Minor modifications are sometimes necessary due to slight vehicle variations, even for the same year, make and model.
- Regardless of year, make and model, a wide range of options for specific applications may or may not interfere with the installation. It is the installer's responsibility to make certain that equipment is not damaged once the suspension solution travels through the full range of motion. Failure to ensure adequate clearance could result in non-warranty property damage, personal injury or even death.
- If running changes were made by the manufacturer after this kit was designed, there may be weldments, braces, gussets, or other structural items which interfere with the installation. It is the installer's responsibility to allow for these running changes without sacrificing the structural integrity of the anti-sway bar. Failure to securely fasten the anti-sway bar could result in property damage, personal injury or even death.
- ROADMASTER will not be responsible for any damage or injury resulting from any modification or alteration.
- Check ALL the fasteners for tightness before and after road testing the vehicle.
- Do not use this document for custom fabrication, as it may not show all parts or structural components.
- Do not use an air impact wrench when re-installing bolts, as stripped threads may result.
- This anti-sway bar is only warranted for the original installation. Installing a used anti-sway bar on another vehicle is not recommended and will void the warranty.

PARTS LIST

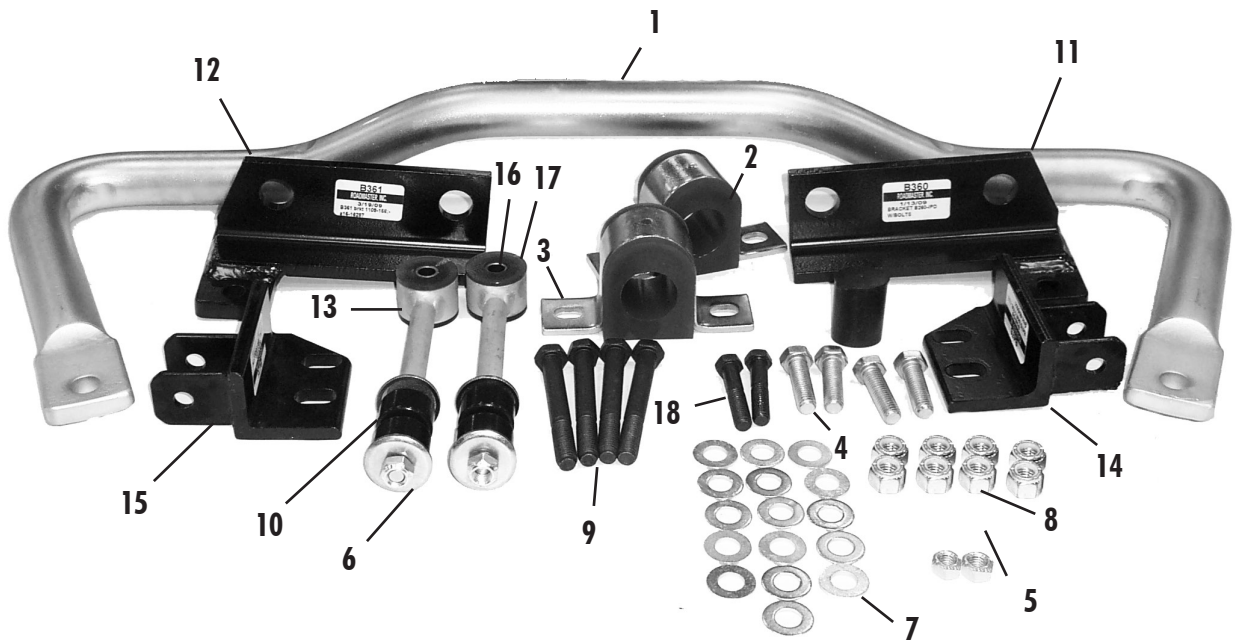

Part #1109-158

Part #	Description	Qty	Part #	Description	Qty
1.	580177-00 Sway bar, 1-5/8"	1	11.	B360 Bracket, axle	1
2.	205222-10 Bushing, poly 1-5/8"	2	12.	B361 Bracket, axle	1
3.	B141 Bracket, u-clamp	2	13.	B477 Endlink	2
4.	350096-80 Bolt, 1/2" x 1-3/4"	4	14.	B476 Bracket, left hanger	1
5.	350256-02 Locknut, 7/16"	2	15.	B475 Bracket, right hanger	1
6.	357434-00 Washer, cup	4	16.	205522-00 Sleeve	2
7.	350308-20 Washer, 1/2"	16	17.	205223-50 Hat bushing	4
8.	350259-00 Locknut, 1/2"	10	18.	350099-80 Bolt, 1/2" x 2-1/2"	2
9.	350105-80 Bolt, 1/2" x 4"	4	19.	400011-30 AQUALUBE Grease	1
10.	205381-00 Grommet, poly	4			

*part not shown

INSTALLATION

- 1** Remove the nuts on the front axle u-bolts.
Locate the u-bolts holding the springs to the axle. Remove only the front two nuts on each side.

- 2** Install the hanger brackets.
Note: the brackets are unique to the left and right side. The welded plate goes on the inside of the leaf spring. Reattach it with the original nuts and washers. Torque to factory torque specs.

- 3** Install the saddle brackets and bushings.
Lubricate the inside of the split bushings and install the bushings on the anti-sway bar near the arms. Slide the saddle brackets over the split bushings.

- 4** Install the anti-sway bar assembly on the hanger brackets.
Lift the anti-sway bar assembly into position so that the saddle bracket holes align with the hanger bracket holes. Use the provided $1/2" \times 1\ 3/4"$ bolts to attach the brackets. Tighten it securely to 60 ft.-lbs.

Be sure to attach the anti-sway bar with the dip hanging down as shown at the right. The arms of the bar go towards the front of truck.

- 5** Attach the endlink brackets to the crossmember.
Using $1/2" \times 4"$ bolts and washers provided, attach the endlink brackets to the engine crossmember using the existing holes. See pictures 5 and 8.

Note: the lip on the angle goes behind crossmember. Do not torque at this time. The bolt holes are slotted to allow for minor adjustments. Use the provided washers and nuts to complete the assembly. Align it so that tabs on bracket point straight down. The notch goes toward the center of the chassis.

- 6** Assemble the endlinks.
Insert two hat bushings and one sleeve into the ring end of the link.

- 7** Attach the endlinks to the brackets.
Using the $7/16" \times 2\ 1/4"$ bolts and nuts, attach the endlinks to the brackets. Tighten until the tabs just contact the endlink bushings.

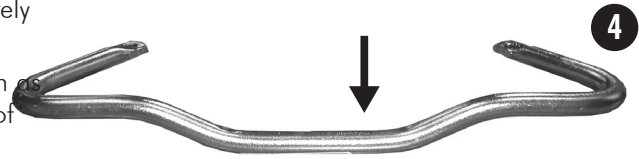
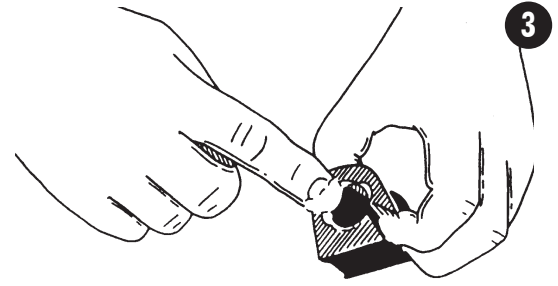

INSTALLATION

8 Attach the endlink to the anti-swaybar.

Place one cup washer and poly grommet on each endlink. Rotate anti-sway bar up and insert endlinks into holes in swaybar ends. Add another grommet and cup washer, install and tighten locknut. Tighten nut until all play is removed. **DO NOT** compress grommets. Align crossmember brackets with endlinks and tighten to 65ft.lbs.

CAUTION! Over tightening on the grommets may cause premature failure of grommets and/or end link bolts.

CAUTION! After road testing, re-check all fasteners for proper tightness.

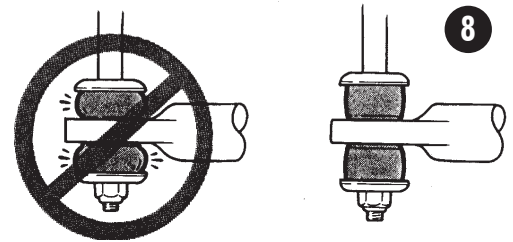
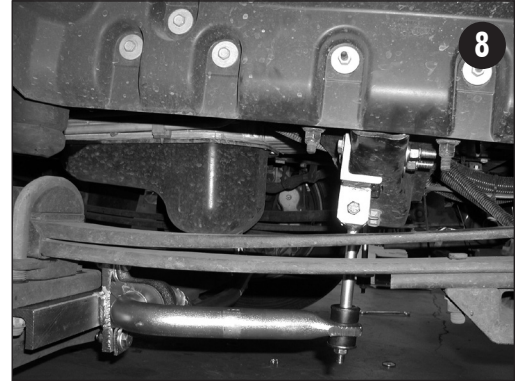

WARNING

Do not tow or hoist the vehicle using the anti-sway bar or its mounting brackets as attachment points. The anti-sway bar is not designed to carry the weight of the vehicle and may collapse, which will damage the anti-sway bar components, the suspension, or other components. The vehicle will detach or fall, which may cause severe personal injury.

Failure to follow these instructions may result in property damage, personal injury or even death.